

SERIES HEATERS

010226, 014372, 014682, 014683, 016501, 016502, 016503, 016504, 017558, 017575



⇒ **FOR SAFETY AND LONG HEATER LIFE, CAREFULLY READ THIS MANUAL BEFORE USE.**

Description

Compact and efficient process air/inert gas heater, capable of producing exit temperatures up to 1400°F (760°C). The serpentine coil element is supported along its entire length by a threaded ceramic rod, and is protected by a quartz tube sheath. The Series heaters are available in either open-ended or nozzled styles. Wattage ranges from 600W to 4000W. If operated correctly, element life will be greater than 5000 hours.

Specifications

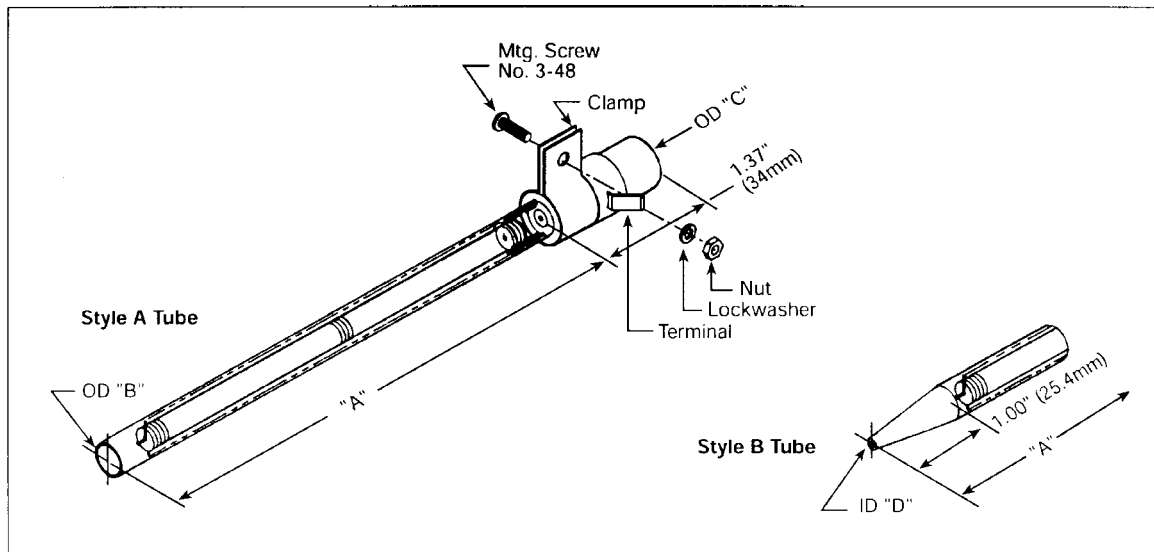

Part Number	Tube Style	Element Material	Max. Watts	Max. Volts	Max. Flow SCFH (SLPM)	Max. Temp. °F (°C)	Tube Length "A"	Tube O.D. "B"	Tube Adapter O.D. "C"	Nozzle I.D. (Style B) "D"
Series I										
010226	A	Ferrous Alloy	1050	80	300 (140)	1200 (650)	6.875" (174.6mm)	0.410" (10.4mm)	0.563" (14.3mm)	—
014372	A	Ferrous Alloy	1000	130	300 (140)	1400 (760)	7.750" (196.9mm)	0.410" (10.4mm)	0.563" (14.3mm)	—
014682	B	Ferrous Alloy	680	145	130 (61)	1200 (650)	7.875" (200.0mm)	0.410" (10.4mm)	0.563" (14.3mm)	0.065" (1.7mm)
014683	B	Ferrous Alloy	650	105	130 (61)	1400 (760)	8.750" (222.3mm)	0.410" (10.4mm)	0.563" (14.3mm)	0.065" (1.7mm)
014679	A	Tungsten	1900	80	300 (140)	1600 (871)	7.750" (196.9mm)	0.410" (10.4mm)	0.563" (14.3mm)	—
014687	B	Tungsten	1550	70	130 (61)	1600 (222.3mm)	8.750" (10.4mm)	0.410" (14.3mm)	0.563" (1.7mm)	0.065"
Series II										
016501	A	Ferrous Alloy	1125	130	300 (140)	1200 (650)	3.875" (98.4mm)	0.410" (10.4mm)	0.563" (14.3mm)	—
016503	A	Ferrous Alloy	850	80	300 (140)	1200 (650)	3.875" (98.4mm)	0.410" (10.4mm)	0.563" (14.3mm)	—
016502	B	Ferrous Alloy	600	95	100 (47)	1200 (650)	4.875" (123.8mm)	0.410" (10.4mm)	0.563" (14.3mm)	0.065" (1.7mm)
016504	B	Ferrous Alloy	650	70	100 (47)	1200 (650)	4.875" (123.8mm)	0.410" (10.4mm)	0.563" (14.3mm)	0.065" (1.7mm)
016508	A	Tungsten	1100	45	300 (140)	1800 (989)	3.875" (98.4mm)	0.410" (10.4mm)	0.563" (14.3mm)	—
016509	B	Tungsten	800	50	100 (47)	1800 (990)	4.875" (123.8mm)	0.410" (10.4mm)	0.563" (14.3mm)	0.065" (1.7mm)
Series III										
017558	A	Ferrous Alloy	2050	160	600 (280)	1600 (871)	6.875" (174.6mm)	0.594" (15.1mm)	0.313" (7.9mm)	—
017575	B	Ferrous Alloy	1450	135	200 (94)	1600 (871)	7.875" (200.0mm)	0.594" (15.1mm)	0.313" (7.9mm)	0.115" (2.9mm)

Maximum recommended pressure 10 PSI (690 mBars)

Safety

- ❑ **SHOCK HAZARD** Only qualified individuals should install this heater and related controls. Follow all applicable electrical codes and use proper wiring.
- ❑ **BURN/FIRE/EXPLOSION HAZARD** Do not use with or near explosive or reactive gases. Avoid contact with the side, or exposure to the exit-end, during or soon after operation. **DO NOT USE NEAR VOLATILE OR COMBUSTIBLE MATERIALS.**

Precautions

- ❑ Use filtered air. Avoid grease, oil, or oil vapors, corrosive or reactive gases that will damage heater.
- ❑ Operate at safe voltages as shown on the PERFORMANCE CURVES. Excess voltage will cause premature failure.
- ❑ Always have sufficient airflow through the heater before applying power. Otherwise element will overheat very quickly, and burn out. **NOTE:** A thermocouple cannot detect temperatures if there is no flow – turn on flow before applying power, even when a controller with a thermocouple is being used.
- ❑ Use phase angle fired power controllers. On-off controllers may shorten heater life (or burnout element).
- ❑ For closed-loop control, use exposed junction type “K” thermocouple within one inch of the heater exit.
- ❑ For closed-loop control, use a temperature controller with a fast sampling period (500ms) and minimal overshoot.

Installation

- Securely mount the heater.
- Connect the filtered air source to the heater.
- If a thermocouple is used, ensure that it is located within one inch from the heater exit.

Start-up

- Reference the PERFORMANCE CURVES section for operational parameters before attempting to operate heater(s).
- Turn on air supply and adjust to desired flow/pressure.
- If using a closed loop system, turn on power to the temperature and power controller, then set the desired temperature on the temperature controller. If using an open loop system, increase power to the heater through the power controller until the desired temperature is attained.

Performance Curves

STYLE A (OPEN ENDED) HEATER CURVES:

The attached performance curves show exit air temperatures at different airflows and voltages. Pressure readings (longer dashed lines) are measured at the inlet to the heater with no entrance or exit restrictions. Solid lines indicate safe, normal life operating conditions. The shorter dash lines indicate marginal, shorter-life operating conditions leading to premature burnout. With a known flow (or pressure) at the heater entrance, follow the flow (or pressure) line across until it meets the desired temperature curve. Drop a line straight down to intersect the x-axis. This point, along the “Heater volts – true RMS” axis, represents the voltage required to generate the desired exit air temperature at the chosen flow rate (inlet pressure).

STYLE B (NOZZLED) HEATER CURVES:

With the small nozzle, it is difficult to measure exit end temperature accurately. Therefore, a different set of performance limits must be used. For these curves, operating with voltages and flows to the left of the curve results in long heater life. Operating to the right of the curve results in heater burn out.

Series I Heater - 010226

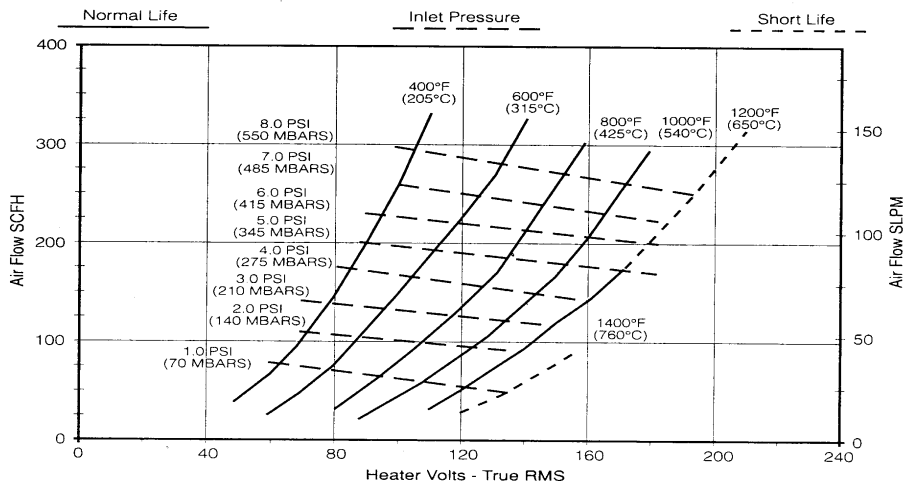

Series I Heater - 014372

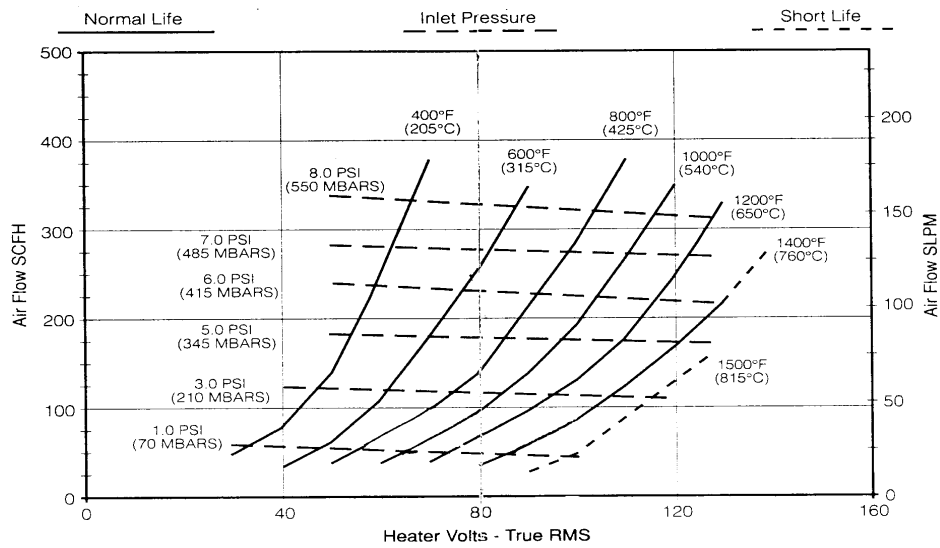

Series II Heater - 016501

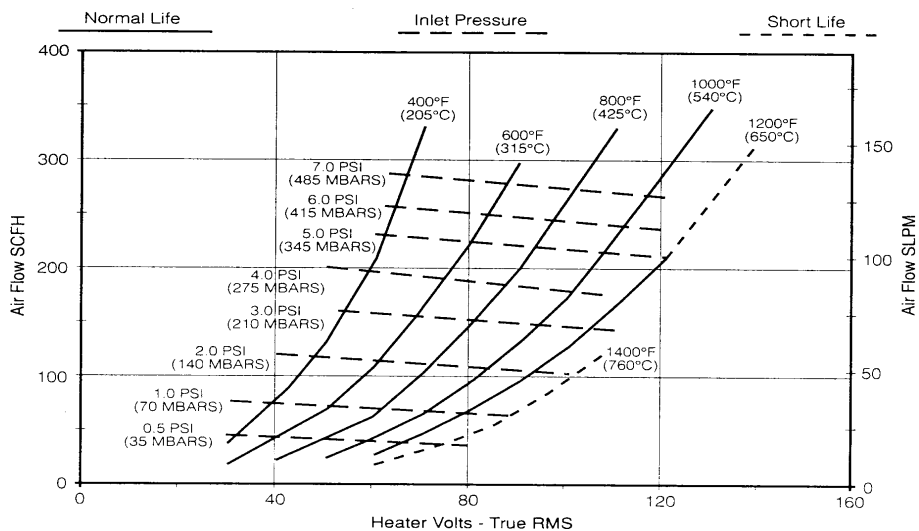

Series II Heater - 016503

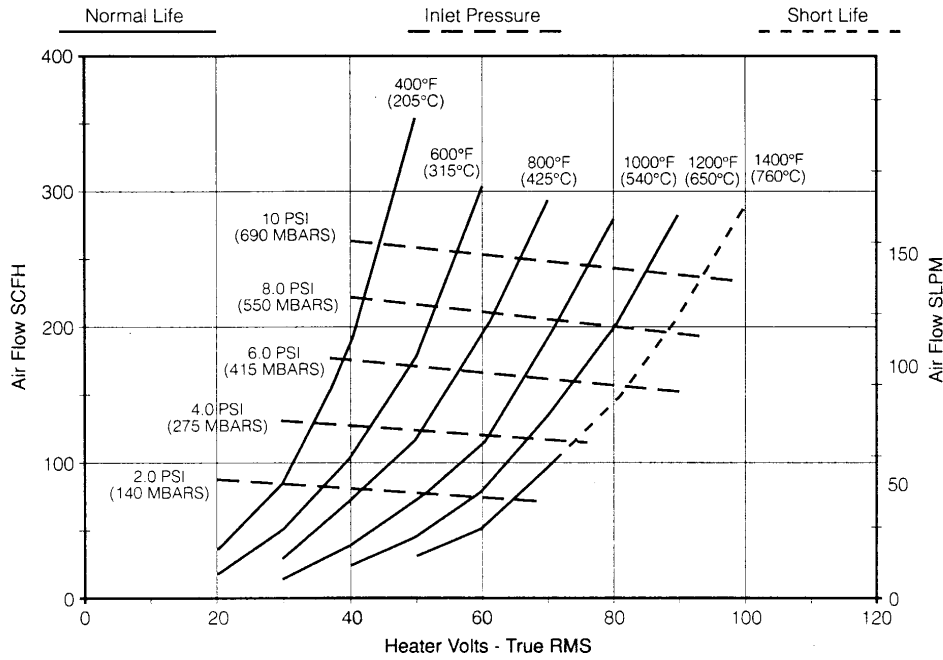

Series III Heater - 017558

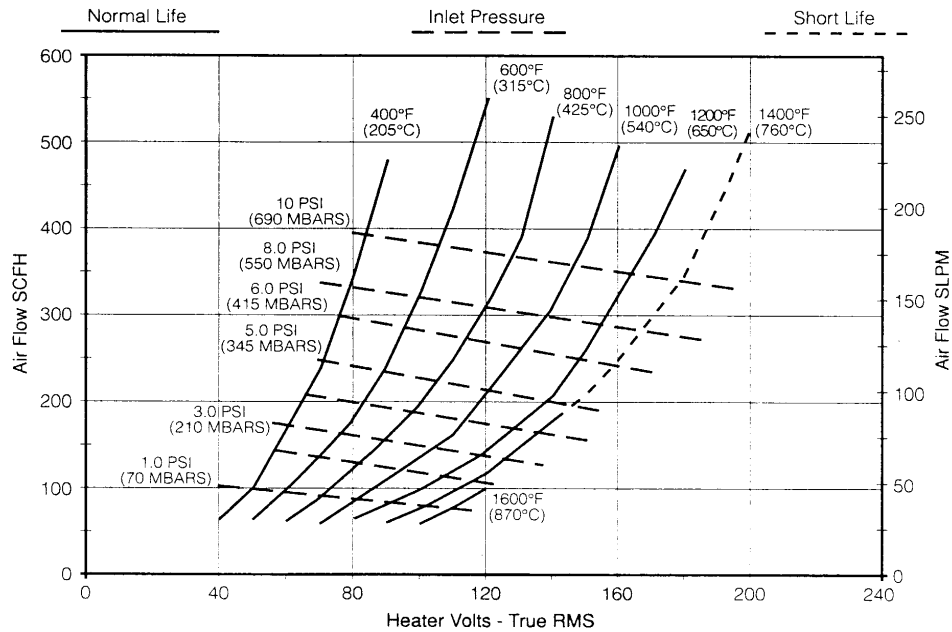

OPERATIONAL LIMITS FOR NOZZLED SERIES II HEATERS (016502)

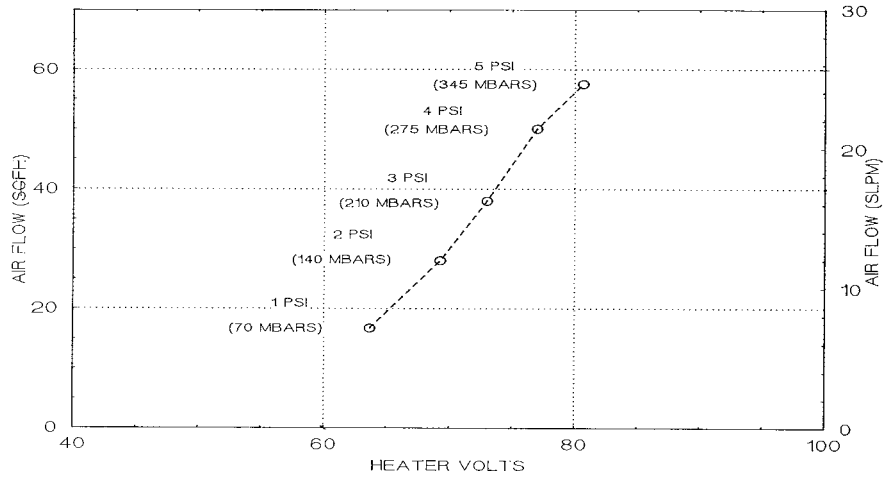

OPERATIONAL LIMITS FOR NOZZLED SERIES I HEATERS (014683)

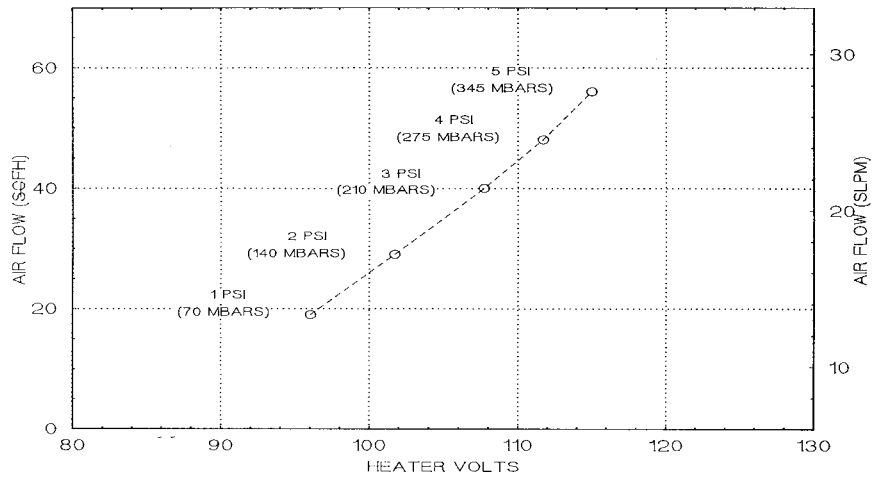

OPERATIONAL LIMITS FOR NOZZLED SERIES I HEATERS (014682)

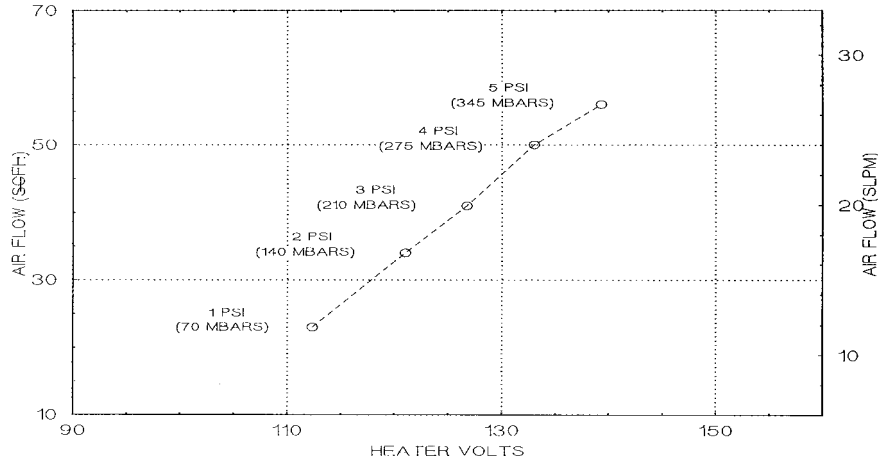

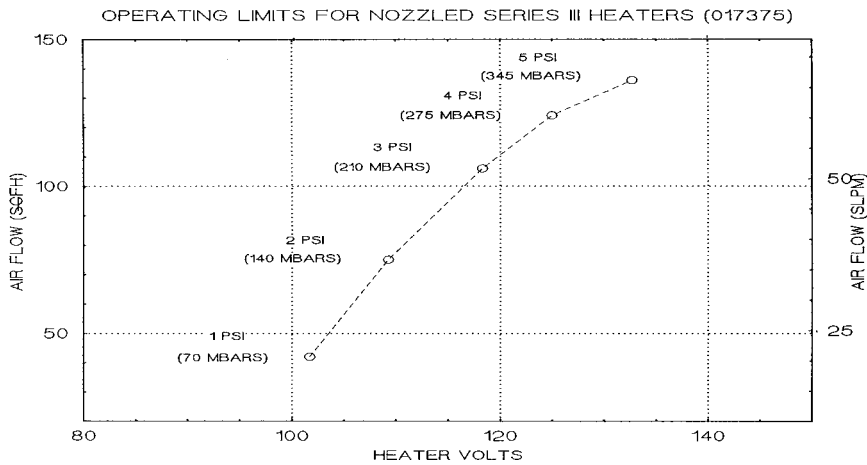
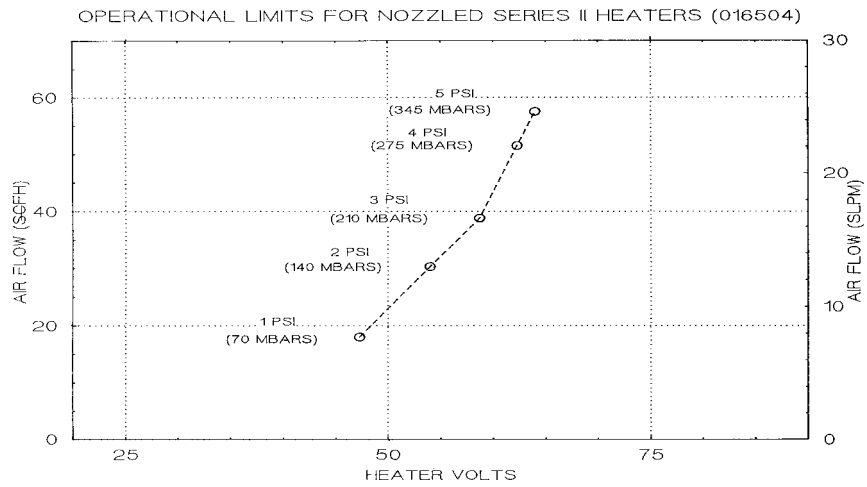

Warranty

OSRAM SYLVANIA warrants that all products to be delivered hereunder will be free from defects in material and workmanship at the time of delivery. OSRAM SYLVANIA's obligation under this warranty shall be limited to (at its option) repairing, replacing, or granting a credit at the prices invoiced at the time of shipment for any of said products. This warranty shall not apply to any such products which shall have been repaired or altered, except by OSRAM SYLVANIA, or which shall have been subjected. OSRAM SYLVANIA shall be liable under this warranty only if (A) OSRAM SYLVANIA receives notice of the alleged defect within sixty (60) days after the date of shipment; (B) the adjustment procedure hereinafter provided is followed, and (C) such products are, to OSRAM SYLVANIA's satisfaction, determined to be defective.

THE WARRANTY SET FORTH IN THE PRECEDING PARAGRAPH IS EXCLUSIVE AND IN LIEU OF ALL OTHER WARRANTIES, EXPRESS OR IMPLIED, INCLUDING, WITHOUT LIMITATION, ANY IMPLIED WARRANTY OF FITNESS FOR A PARTICULAR PURPOSE OR OF MERCHANTABILITY.

The information contained in this manual is based on data considered to be true and accurate. Reasonable precautions for accuracy has been taken in the preparation of this manual, however OSRAM SYLVANIA assumes no responsibility for any omissions or errors, nor assumes any liability for damages that may result from the use of the product in accordance with the information contained in this manual.

Please direct all warranty/repair requests or inquiries to the place of purchase, and provide the following information, in writing:

- (A) Order number under which products were shipped
- (B) Model/Serial Number of product
- (C) Reason for rejection

PRODUCTS CAN NOT BE RETURNED TO OSRAM SYLVANIA WITHOUT AUTHORIZATION.

Replacement, repair, or credit for products found to be defective will be made by the place of purchase. All products found to be not defective will be returned to the Buyer; transportation charges collect or stored at Buyers expense.