



NEMA 4X INDUSTRIAL CONTROLS

T109 AND T115 SERIES RAINTIGHT, WEATHER RESISTANT THERMOSTATS



HIGHLIGHTS

- One Control for Heating and/or Cooling
- NEMA 4X Enclosure Complies with N.E.C. Article 547
- Rugged, Weather Resistant Enclosure
- Corrosion Resistant Materials for Long Life
- Low Mass, High Surface Area of Sensors Provide Rapid Response to Temperature Change
- Local and Remote Sensing Models Available
- Large, Readily Visible Dial
- Multi-Positional Mounting Offers Flexibility in New or Existing Installations
- High Level of Accuracy and Sensitivity
- Meets UL and CSA Requirements
- TH109 Features Two SPDT Staged Switches

The PECO T109 and T115 NEMA 4X thermostats are intended for applications that require a rugged, weatherproof control. Typical applications include refrigeration, walk-in coolers, freezers, ventilation fans, dampers, and heating and cooling in factory buildings, greenhouses, garages, warehouses or animal confinement buildings for poultry, hogs or livestock. The unit will tolerate spraying with water, high humidity, airborne contaminants and moderately corrosive conditions.

Put Our Experience to Work for You

Since 1938, PECO has been known for highly engineered products that set the standard for quality, performance, and reliability. Now you can buy from the best for less.

TECHNICAL SPECIFICATIONS



TECHNICAL SPECIFICATIONS

	TH109-009	TF115-001	TRF115-005	TRF115-007
Temperature Range	40 to 100°F / 4 to 37°C	40 to 110°F / 4 to 43°C	0 to 120°F / -18 to 49°C	-30 to 100°F / -34 to 38°C
Sensor	Stainless Steel Coiled Bulb	Stainless Steel Coiled Bulb	60" Stainless Steel Bulb/Capillary	8' (2.44m) Copper Bulb/Capillary
Switch	SPDT (2)	SPDT	SPDT	SPDT
Remote Temperature Sensing	No	No	Yes	Yes
Enclosure	NEMA 4X Thermoplastic	NEMA 4X Thermoplastic	NEMA 4X Thermoplastic	NEMA 4X Thermoplastic
Control	Dial Knob	Dial Knob	Dial Knob	Dial Knob
Agency Approvals	UL, CSA	UL, CSA	UL, CSA	UL, CSA

Note: For NEMA 4X installation, NEMA 4X connectors must be used.

RATINGS

VOLTAGE RATING	FULL LOAD	LOCKED ROTOR	NON-INDUCTIVE	PILOT DUTY
120 VAC	16.0A	80.0A	25.0A	125VA
208 VAC	13.2A	66.0A	25.0A	125VA
240 VAC	12.0A	60.0A	25.0A	125VA
277 VAC	10.0A	50.0A	22.0A	125VA

SUITABLE FOR 24 VAC OPERATION

WIRING DIAGRAMS

TH109-009

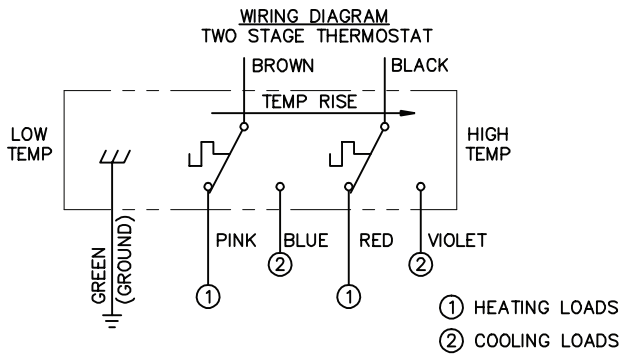

THERMOSTAT OPERATION: DOUBLE POLE, DOUBLE THROW CONTACTS OPERATE SEQUENTIALLY WITH 3°F (1.7°C) NOMINAL SEPARATION ON TEMPERATURE RISE OR FALL. AT TEMPERATURE ABOVE THE SET POINT, LEADS BLACK/VIOLET AND BROWN/BLUE ARE CLOSED. ON TEMPERATURE FALL TO 3°F (1.7°C) (NOMINAL) ABOVE THE SET POINT, LEADS BLACK/RED CLOSE AND BLACK/VIOLET OPEN. ON FURTHER TEMPERATURE FALL TO THE SET POINT, LEADS BROWN/PINK CLOSE AND BROWN/BLUE OPEN.

TH109-009 CONNECTION OPTIONS

Two Speed Cooling Equipment

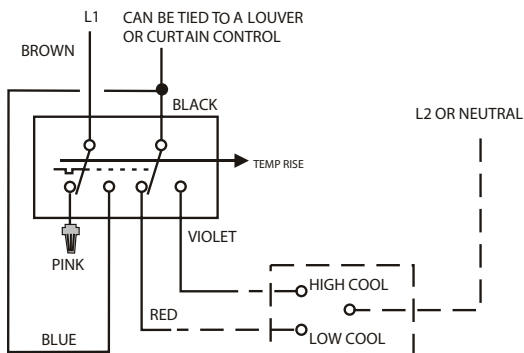

Two Speed Heating Equipment

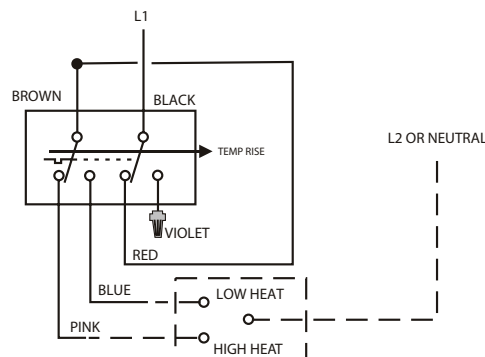

Two Stage Cooling Equipment

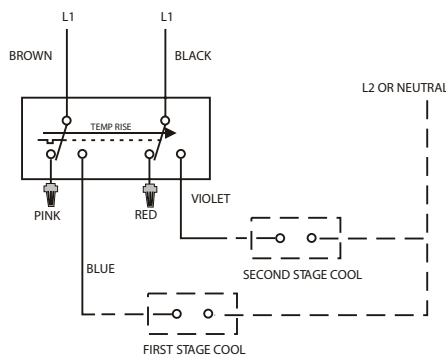

Two Stage Heating Equipment

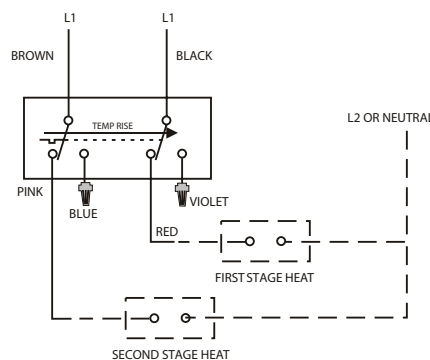

Auto Changeover Control

1 Heat/1 Cool with 3°F dead band

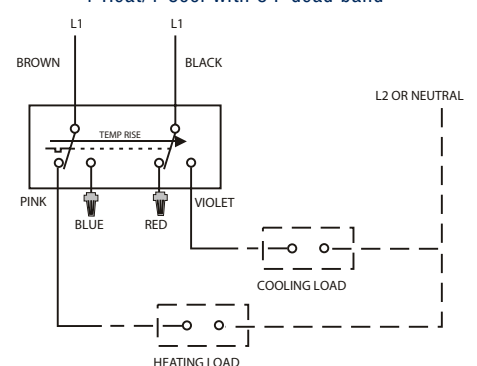

TF115-001, TRF115-005, TRF115-007

- For local sensing applications the coiled capillary bulb can be tie-wrapped to the bottom tang.

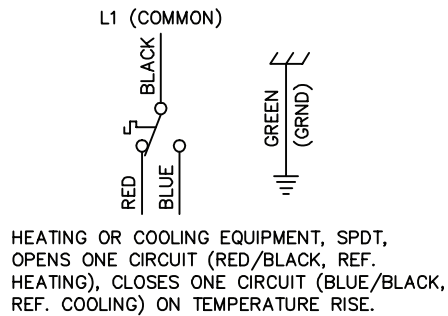

MOUNTING INSTRUCTIONS

TH109-009

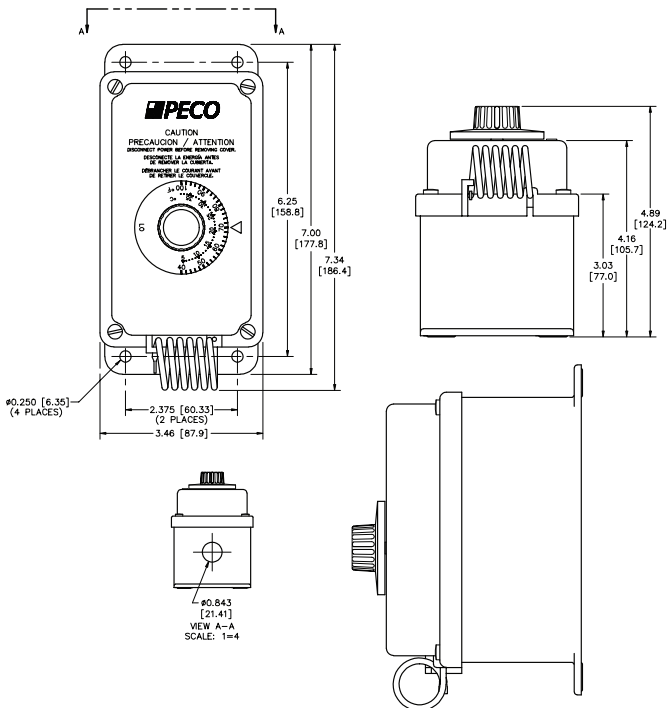

TF115-001

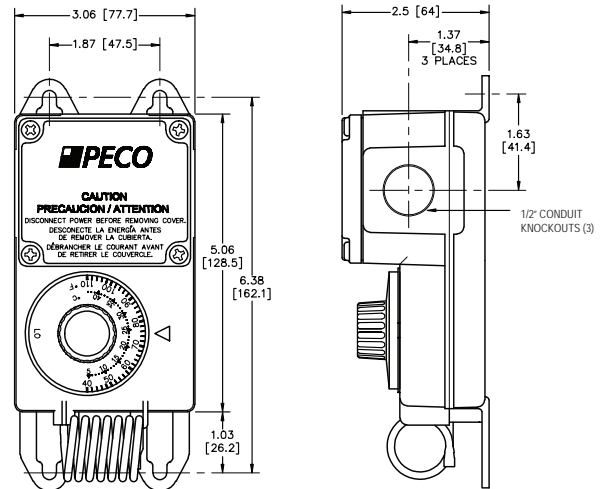

TRF115-005

TRF115-007

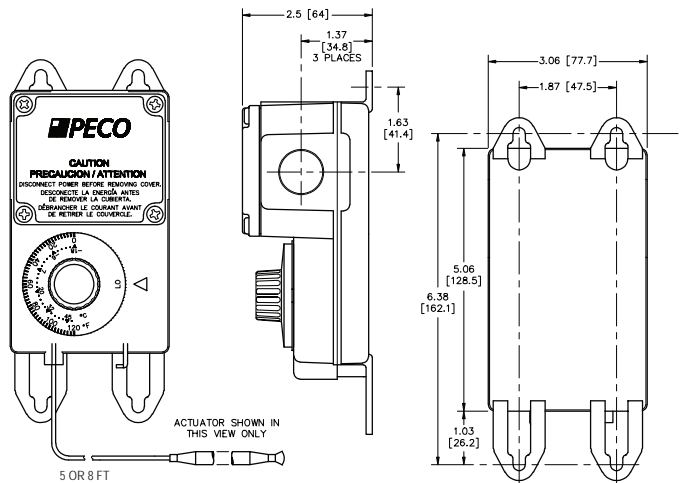

MODEL SELECTION GUIDE

MODEL	PART NUMBER	DESCRIPTION
TH109-009	68427	NEMA 4X thermostat, stainless steel coiled bulb, 40 to 100°F / 4 to 37°C
TF115-001	68471	NEMA 4X thermostat, stainless steel coiled bulb, 40 to 110°F / 4 to 43°C
TRF115-005	68426	NEMA 4X thermostat, 60" stainless steel bulb/capillary, 0 to 120°F / -18 to 49°C
TRF115-007	69320	NEMA 4X low temperature thermostat, 8' copper bulb/capillary, -30 to 100°F / -34 to 38°C



Automation and Controls
Division of PECO, Inc.
PO Box 82189, Portland, OR 97282

Phone: 800-874-8547 / 503-233-6401
Email: sales@pecomanufacturing.com
www.pecomanufacturing.com